

Agilent EPM-P Series Single- and Dual-Channel Power Meters Agilent E9320 Family of Peak and Average Power Sensors

Product Overview

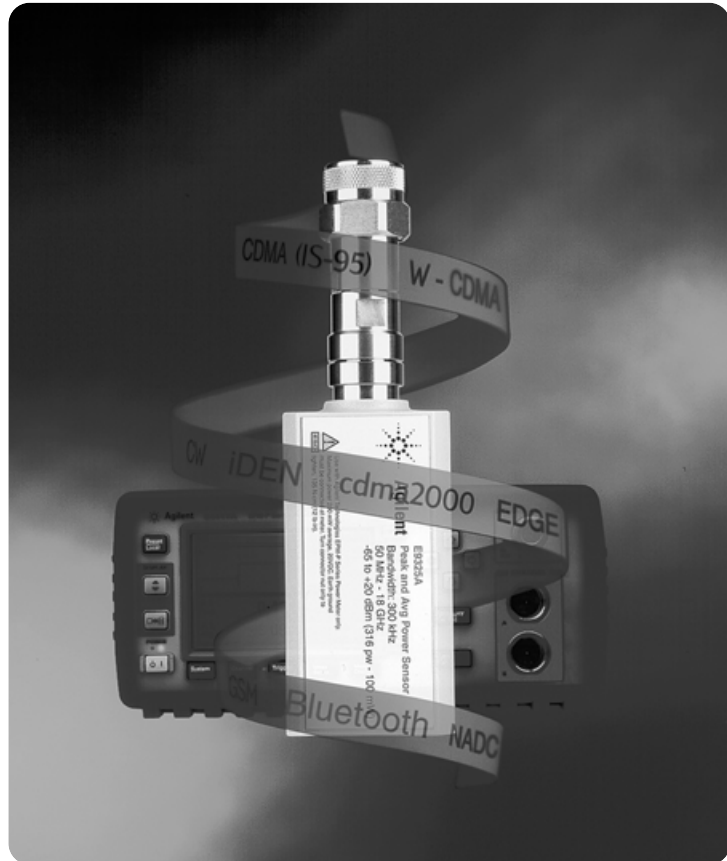

The power measurement solution you've been looking for

- Ideal for today's R&D and manufacturing environments
- Peak, average, peak to average ratio, and time-gated measurements for TDMA, CDMA, and W-CDMA testing
- Speed, accuracy, and reliability for greater throughput without compromise
- 5 MHz bandwidth (maximum), high-performance peak and average power sensors
- Analyzer software for power, time, frequency and statistics



Agilent Technologies

Designed for manufacturing

Agilent has the power measurement solution you've been looking for

In a competitive environment such as wireless manufacturing, testing needs to be as efficient as the rest of the manufacturing process. If you are looking for a single-meter solution that can do a full range of power measurements with speed, accuracy, and reliability, you'll find all these capabilities and more in Agilent's EPM-P series power meters and E9320 power sensors.

Two EPM-P series models offer excellent performance optimized for wireless communications testing:

- E4416A single-channel meter, 9 kHz to 110 GHz, sensor dependent
- E4417A dual-channel meter, 9 kHz to 110 GHz, sensor dependent

Together with the E9320 power sensors, the EPM-P power meters measure the complex modulation formats of today's TDMA and CDMA standards, as well as emerging wide-band CDMA (W-CDMA) standards for 3G wireless communications.

Power meter measurements include peak, peak-to-average ratio, and average power of RF and microwave signals. Extensive triggering features are available for making time-gated measurements. Fast test times, with measurement speed of up to 1,000 corrected readings per second, help you increase throughput to meet time-to-market and time-to-volume goals.

High-performance power sensors

The EPM-P series power meters work with the E9320 peak and average power sensors to create a low-cost solution that answers a wide range of manufacturing test needs.

Six power sensors make up the E9320 family:

- E9321A, 50 MHz to 6 GHz, 300 kHz bandwidth
- E9322A, 50 MHz to 6 GHz, 1.5 MHz bandwidth
- E9323A, 50 MHz to 6 GHz, 5 MHz bandwidth
- E9325A, 50 MHz to 18 GHz, 300 kHz bandwidth
- E9326A, 50 MHz to 18 GHz, 1.5 MHz bandwidth
- E9327A, 50 MHz to 18 GHz, 5 MHz bandwidth

Each sensor offers variable bandwidth settings so that you can maximize the sensor's dynamic range for your application.



One meter for TDMA, CDMA, and W-CDMA power measurements

The EPM-P series power meters with the E9320 family sensors provide peak power, average power, peak-to-average ratio, and time-gated measurements of the complex modulation formats in wireless communication systems.

Time-gated measurements are performed using the meter's extensive triggering features, which include continuous, level, external TTL, and GPIB triggering. A TRIGGER OUT port, on the rear panel, allows other equipment to be synchronized to the power meter measurements, simplifying measurement setups.

The flexible user interface allows you to perform and display up to four simultaneous time-gated or free-running measurements. For time-gated measurements, each gate can be set up to measure the average, peak, or peak-to-average ratio, and you can set individual start and duration times for each measurement. This capability is

Speed without sacrificing accuracy and repeatability

Faster test times help improve manufacturing productivity and efficiency. Designed for both bench and ATE operation, the EPM-P power meters and E9320 sensors provide a measurement speed, over the GPIB, of up to 1,000 corrected readings per second. The power meters' 20 M-samples per second continuous sampling rate gives you the ability to accurately profile complex modulation formats of up to 5 MHz bandwidth, and modulation bandwidth correction ensures accurate peak measurements on signals such as CDMA or W-CDMA.

especially useful for measuring power on TDMA signals that require time-gating of various combinations of peak and average power. On a GSM signal, for example, you can use time-gating to measure the average power of the "useful" time period (5% - 95% of the burst duration), as well as to measure the peak power, peak-to-average ratio, and pulse droop.

Gate 2 provides the burst average power over the "useful" GSM time period and Gate 1 indicates the peak power over the complete timeslot. A peak-to-average ratio measurement can therefore be obtained by combining Gate 1 - Gate 2 (in dB). This peak-to-average measurement is made on two different gate times and should not be confused with the peak-to-average ratio measurement that can be carried out in a single gate. A pulse droop measurement can be obtained from the subtraction of the two powers, Gate 4/Gate 3.

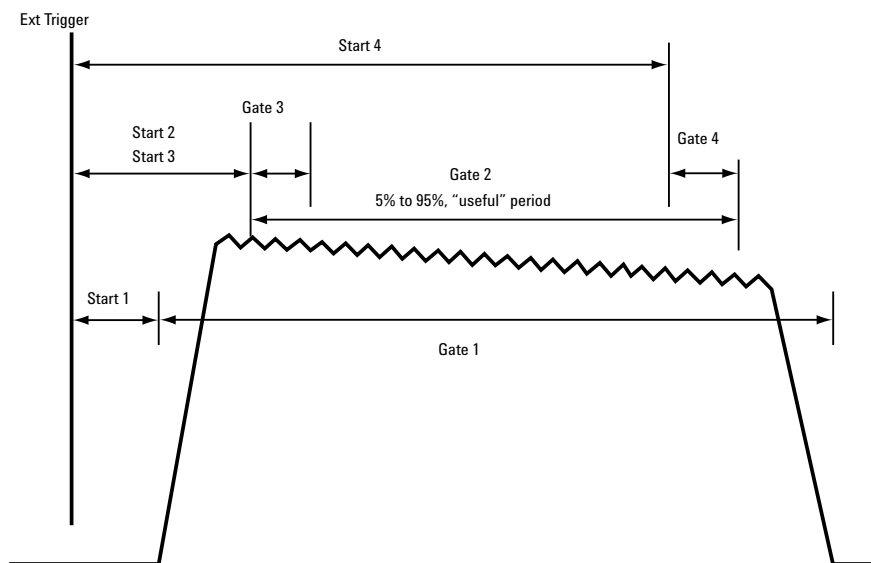

Designed for R&D

In a design and verification environment the EPM-P series power meters now offer a complete solution for power measurements.

Real time markers allow closer analysis of the signal under test. The gate control screen provides graphical signal representation of delta time, delta average, and delta peak and delta peak-to-average ratio with respect to markers 1 and 2 on the display. The trace control feature provides a trace zoom feature for closer examination of a signal. Ideal for investigating glitches and overshoot, and for closer examination of the rise time or fall time.

Measurement gates can be set by numerical entry of the start and length time. Also through the use of the graphical gate set up to define and control the start and length of the gate.



Best in class calibration reference

The 1 mW power reference provides low measurement uncertainty for power sensor calibration and ensures a power output traceable to the U.S. National Institute of Standards and Technology (NIST) and the National Physical Laboratories (NPL), UK.

Thorough analysis and verification of the power meter test processes allow Agilent to provide best-in-class 0 dBm calibration reference

specifications. Temperature banding of accuracy over one-year and a warranted SWR specification mean that you can test to tighter specifications within your operating environment with confidence in your measurement results.

Accuracy (for one-year):
±1.2% (0°C to 55°C)
±1.07% (25°C ±10°C);
±1.03 (23°C ±3°C);
SWR: 1.05 maximum

Agilent EPM-P analyzer software

The Agilent EPM-P analyzer software is a PC based tool for pulse and statistical analysis for TDMA and CDMA modulation formats.

Pulse analysis

Versatile markers offer complete power and timing characterization¹ of pulsed signals, to provide easy testing of TDMA component parameters and system performance. In addition to measuring the peak power, average power and the peak-to-average ratio, the Agilent EPM-P analyzer software measures the following pulse characteristics automatically:

Power

- Pulse Top
- Pulse Base
- Distal
- Mesial
- Proximal
- Overshoot
- Burst Average

Frequency and time

- Pulse Repetition Frequency (PRF)
- Pulse Repetition Interval (PRI)
- Pulse Width
- Off-time
- Rise time
- Fall time

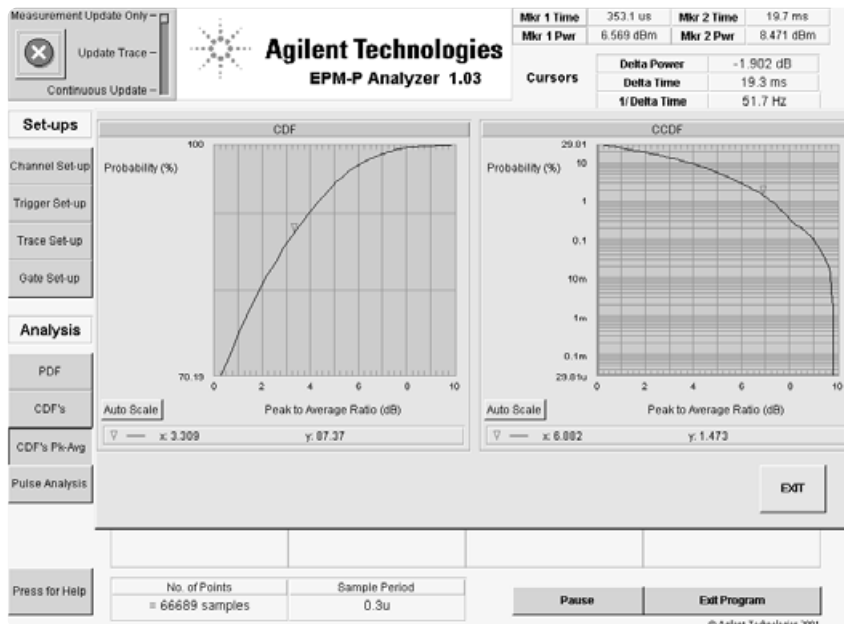
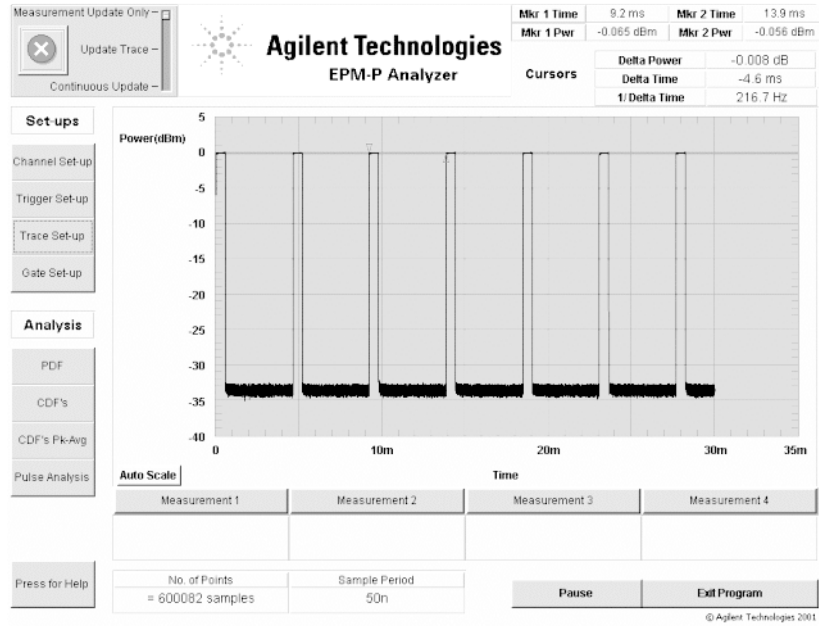

Statistical analysis

For today's noise-like CDMA and W-CDMA formats, statistical analysis of the power distribution provides essential characterization to optimize system design, such as testing for amplifier compression. The Agilent EPM-P Analyzer software provides the capability to determine the Probability Distribution Function (PDF), Cumulative Distribution Function (CDF), and Complementary Cumulative Distribution Function (1-CDF or CCDF).

¹ Pulse characterization is only for the captured trace length.

A power meter that is very easy to use

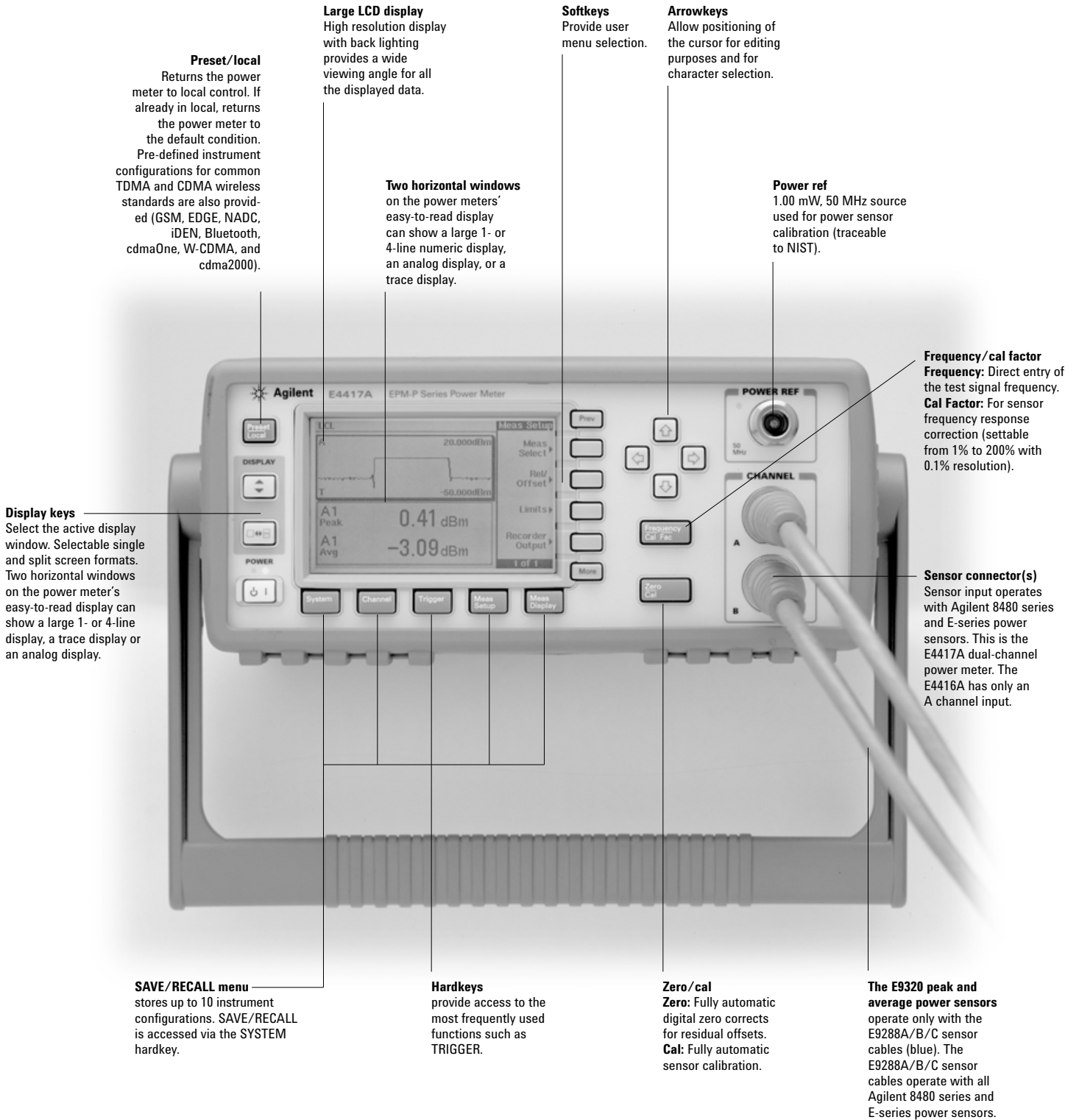

Preset/local

Returns the power meter to local control. If already in local, returns the power meter to the default condition. Pre-defined instrument configurations for common TDMA and CDMA wireless standards are also provided (GSM, EDGE, NADC, iDEN, Bluetooth, cdmaOne, W-CDMA, and cdma2000).

Large LCD display

High resolution display with back lighting provides a wide viewing angle for all the displayed data.

Softkeys

Provide user menu selection.

Arrowkeys

Allow positioning of the cursor for editing purposes and for character selection.

Two horizontal windows

on the power meters' easy-to-read display can show a large 1- or 4-line numeric display, an analog display, or a trace display.

Power ref

1.00 mW, 50 MHz source used for power sensor calibration (traceable to NIST).

Frequency/cal factor

Frequency: Direct entry of the test signal frequency. **Cal Factor:** For sensor frequency response correction (settable from 1% to 200% with 0.1% resolution).

Display keys

Select the active display window. Selectable single and split screen formats. Two horizontal windows on the power meter's easy-to-read display can show a large 1- or 4-line display, a trace display, or an analog display.

Sensor connector(s)

Sensor input operates with Agilent 8480 series and E-series power sensors. This is the E4417A dual-channel power meter. The E4416A has only an A channel input.

SAVE/RECALL menu

stores up to 10 instrument configurations. SAVE/RECALL is accessed via the SYSTEM hardkey.

Hardkeys

provide access to the most frequently used functions such as TRIGGER.

Zero/cal

Zero: Fully automatic digital zero corrects for residual offsets. **Cal:** Fully automatic sensor calibration.

The E9320 peak and average power sensors

operate only with the E9288A/B/C sensor cables (blue). The E9288A/B/C sensor cables operate with all Agilent 8480 series and E-series power sensors.

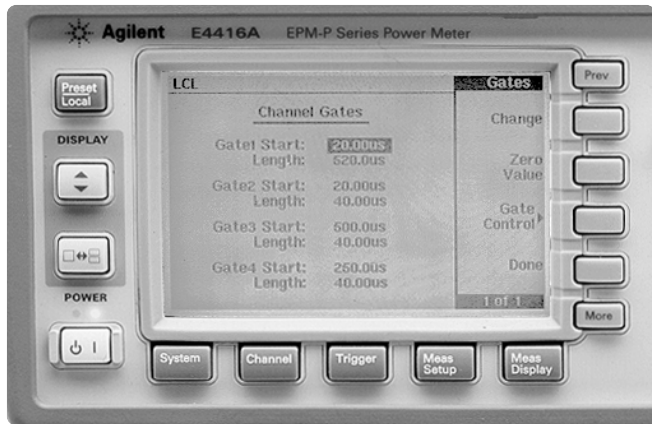

Versatile user interface displays up to four time gates and lengths in a single measurement setup. This menu is accessed using the CHANNEL hardkey.

Large character mode provides easy viewing of information from a distance.

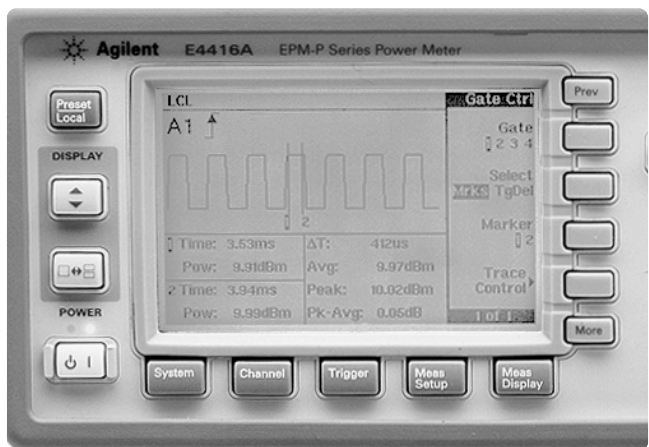
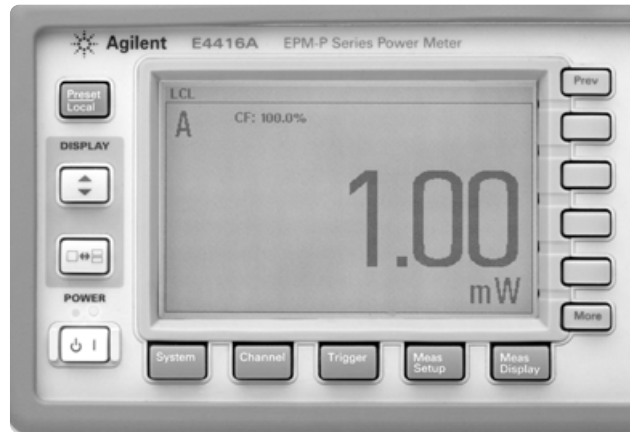

Markers 1 and 2 show the instantaneous power and time relative to the trigger event.

Easy to learn ... easy to use

Increase your productivity with an easy-to-learn, easy-to-use power meter.

The EPM-P series has been designed with the user in mind. Hardkeys such as ZERO/CAL allow access to the most frequently used power meter functions. Softkeys provide measurement control through user selection. The high resolution LCD display (with backlighting), large characters, and split screens provide easy viewing of information.

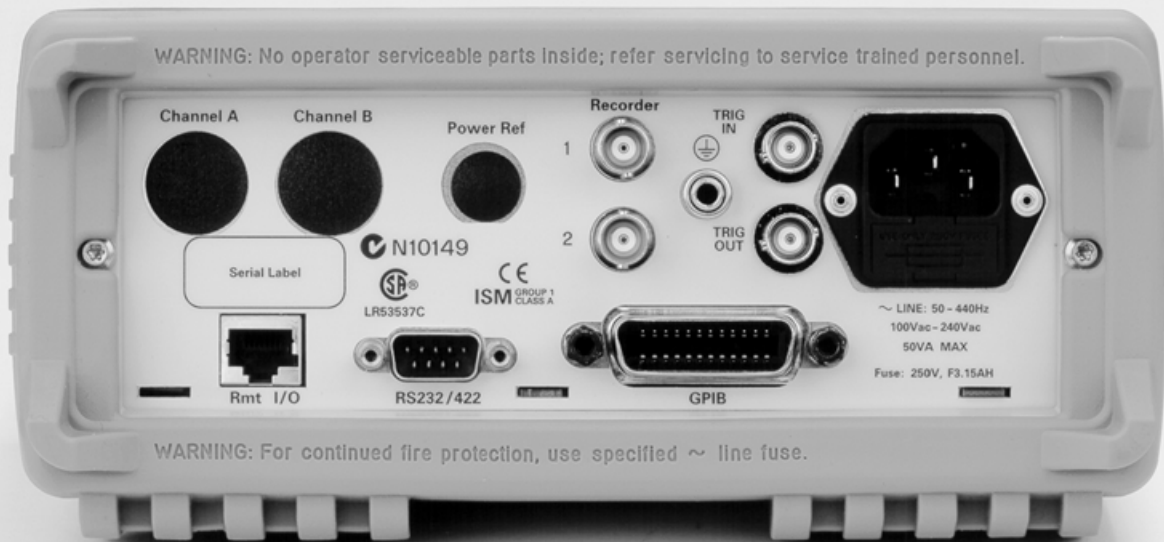

Rear panel features

- DC Recorder Output, 0 to 1 Volt. The Agilent E4417A has two dc Recorder Outputs as shown.
- E441xA-002 provides parallel rear panel sensor inputs with the power reference oscillator on the front panel.
- E441xA-003 provides parallel rear panel sensor inputs and moves the power reference oscillator to the rear panel.
- GPIB connector for remote control of all functions.
- RS232/422 connector for remote control.
- Line power - universal input voltage range with NO range selection switches.
- Ground connector - for those applications where you need a hard-wired connection between the power meter's ground and a common ground.
- Power meter conforms to CE and CSA standards.
- Remote input / output - TTL logic level is output when a measurement exceeds a predetermined limit. TTL inputs are provided to initiate zero and calibration cycles.
- Trig In - accepts a TTL signal for initiating measurements.
- Trig Out - outputs a TTL signal for synchronizing with external equipment.

High-performance, high-value power sensors

The E9320 power sensors have two frequency ranges—from 50 MHz to 6 GHz, which covers most wireless communication applications, and from 50 MHz to 18 GHz. For each frequency range there is a choice of sensors with three modulation bandwidths:

- 300 kHz, for measuring TDMA signals such as GSM
- 1.5 MHz, for measuring IS-95 CDMA signals
- 5 MHz, for measuring W-CDMA signals.

Variable bandwidths to maximize dynamic range

Wider bandwidths allow you to profile fast-changing signals, but at the expense of dynamic range. So that you can select the best video bandwidth¹ for your application and still maintain the widest possible dynamic range, Agilent

gives each E9320 sensor three video bandwidth settings—the maximum (default) setting, a medium setting, and a low setting.

Using the three settings, for example, you can use a single E9323A 5-MHz sensor to measure W-CDMA, IS-95 CDMA, and GSM signals.

| E9323A video bandwidth | Maximum peak power dynamic range |
|------------------------|----------------------------------|
| High (default): 5 MHz | –32 to +20 dBm |
| Medium: 1.5 MHz | –34 to +20 dBm |
| Low: 300 kHz | –36 to +20 dBm |

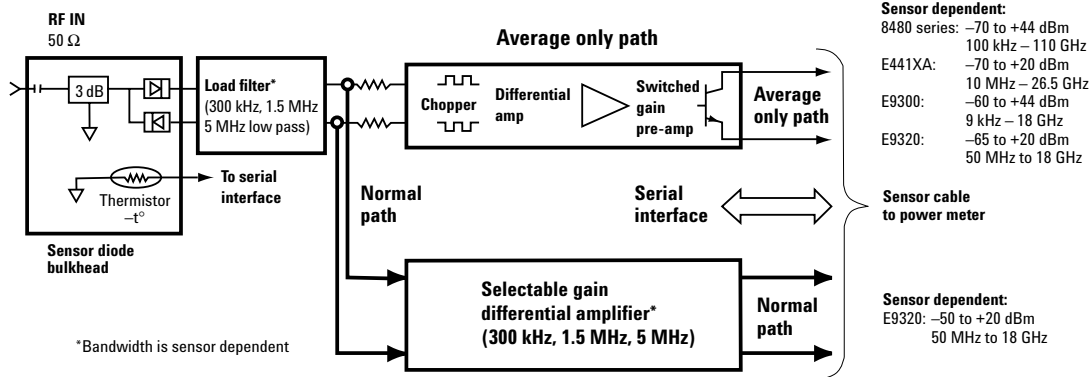

Two sensors in one package

The E9320 power sensors also combine stable, low-level power measurements with modulation measurements, to meet a wider range of test needs. The sensors have two independent measurement paths, providing the exceptional value of two sensors in one package:

- **Normal path** for high-speed, continuously sampled measurement of modulated signals and time-gated measurements. This is the default path for E9320 sensors.
- **Average only path** for average power measurements on all signal types between –65 to –20 dBm. CW power measurements can be made between –65 to +20 dBm.

¹ The video bandwidth is the bandwidth detectable by the sensor and meter over which the power is measured, and is sometimes referred to as the modulation bandwidth.

Measurement accuracy and repeatability

For even greater accuracy and ease of use, the E9320 power sensors' calibration factors, linearity, temperature and bandwidth compensation data are all stored in EEPROM. At power-on or when the sensor is connected to an EPM-P series power meter, all the compensation data (for the calibration factors, linearity, temperature and bandwidth correction) is automatically downloaded from the sensor into the power meter. That means you achieve optimum accuracy no matter the signal parameters and measurement temperature.

In power measurement, mismatch between the sensor and the source is one of the main contributors to overall measurement uncertainty. To minimize this effect, the E9320 sensors provide exceptionally low standing wave ratio (SWR). For example, SWR is 1.12 for signals less than 0 dBm from 50 MHz to 2 GHz. Low SWR means that mismatch uncertainty has been minimized and measurement accuracy improved.

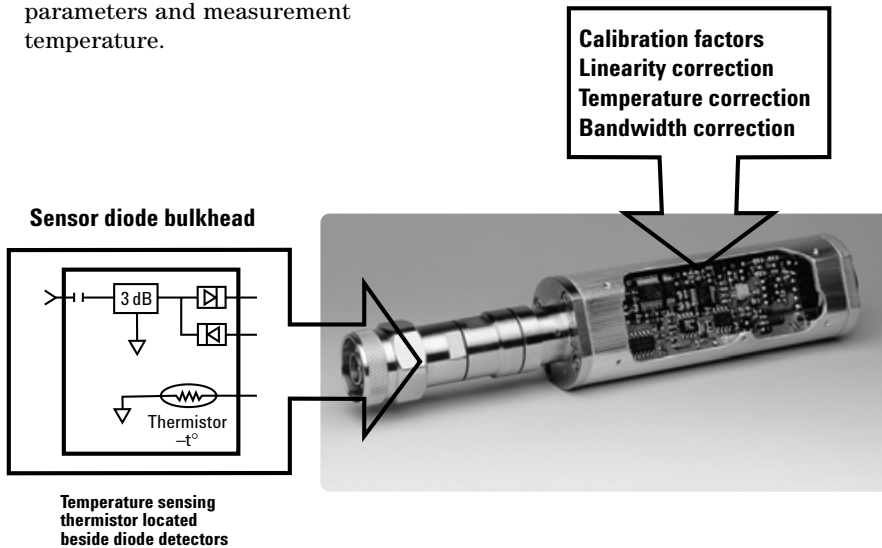

Compatibility with more than 30 Agilent sensors

The EPM-P series power meters are also compatible with Agilent's 8480 and E-series power sensors, which gives you additional choices for conventional, average power measurements. Including the E9320 family, Agilent provides a selection of more than 30 compatible sensors that cover a wide range of manufacturing and R&D needs.

Code compatibility

The EPM-P series power meters do not have code compatibility with the discontinued 43X power meters, and the 8900C/D peak power meters. The EPM-P series power meters use SCPI programming, therefore for average power measurements, most commands will be compatible with the EPM series power meter.



New sensor cable

All Agilent E9320 power sensors must be used with an E9288A, B, or C sensor cable. You can also use this cable with the all Agilent 8480 and E-series power sensors. The E9288A, B and C sensor cables are easily identified by their blue color.

EPM-P power meter options and accessories

EPM-P series power meters

- E4416A Single channel EPM-P series power meter
- E4417A Dual channel EPM-P series power meter

Options available

Connectors

- E441xA-002 Parallel rear panel sensor input connector(s) and front panel reference calibrator
- E441xA-003 Parallel rear panel sensor input connector(s) and rear panel reference calibrator connector

Calibration documentation

- E441xA-A6J ANSI Z540 compliant calibration test data including measurement uncertainties

Documentation

A hard copy of the Installation Guide and CD of the English language User's Guide and Programming Guide are provided with the EPM-P power meter as standard. A selection can be made to delete the hardcopy.

- E441xA-0B0 Delete manual set

Additional documentation

Selections can be made for the localization of the User's Guide, with an English language Programming Guide and Service Manual.

- E441xA-0B3 English language Service Manual
- E441xA-0BK English language manual set (hardcopy User's Guide and English Programming Guide)
- E441xA-ABD German localization (hardcopy User's Guide and English Programming Guide)
- E441xA-ABE Spanish localization (hardcopy User's Guide and English Programming Guide)
- E441xA-ABF French localization (hardcopy User's Guide and English Programming Guide)
- E441xA-ABJ Japanese localization (hardcopy User's Guide and English Programming Guide)
- E441xA-ABZ Italian localization (hardcopy User's Guide and English Programming Guide)

Cables

- E441xA-004 Delete power sensor cable

Additional cables

For operation with the E9320 power sensors:

- E9288A Power sensor cable, length 5 feet (1.5 meters)
- E9288B Power sensor cable, length 10 feet (3 meters)
- E9288C Power sensor cable, length 31 feet (10 meters)

Accessories

- E441xA-908 Rack mount kit (one instrument)
- E441xA-909 Rack mount kit (two instruments)
- 34131A Transit case for half-rack 2U high instruments
- 34141A Yellow soft carry/operating case
- 34161A Accessory pouch

Path to the future

Agilent is committed to providing long-term solutions for the measurement of RF and microwave power. To exemplify this commitment, we will enhance the EPM-P series power meters in the future with new product features. These features will be provided as upgrades to the instruments' firmware available as downloads from the Internet or on disk.

To find out more about new product features, visit our Web site at:

www.agilent.com/find/powermeters

Warranted support

The Agilent EPM-P power meters and E9320 power sensors come with a standard 1-year warranty.

For more information

Agilent provides free, detailed product and application notes that explain how to achieve the best accuracy and repeatability from your EPM-P power meter and E9320 power sensors. Some of these are listed below:

Choosing the Right Power Meter and Sensor, Product Note,
literature number 5968-7150E

Fundamentals of RF and Microwave Power Measurements, Application Note 64-1,
literature number 5965-6630E

4 Steps for Better Power Measurements, Application Note 64-4,
literature number 5965-8167E

Related literature

EPM-P Series Power Meters and E9320 Power Sensors, Technical Specifications,
literature number, 5980-1469E

EPM-P Series Power Meters, EPM Series Power Meters and E-series Power Sensors, Configuration Guide,
literature number 5965-6381E

EPM-P Series Single-and Dual-Channel Power Meters, Demo Guide,
literature number 5988-1605EN

EPM-P Series Power Meter and CD Rom
literature number E4416-90032

Agilent Technologies' Test and Measurement Support, Services, and Assistance

Agilent Technologies aims to maximize the value you receive, while minimizing your risk and problems. We strive to ensure that you get the test and measurement capabilities you paid for and obtain the support you need. Our extensive support resources and services can help you choose the right Agilent products for your applications and apply them successfully. Every instrument and system we sell has a global warranty. Support is available for at least five years beyond the production life of the product. Two concepts underlie Agilent's overall support policy: "Our Promise" and "Your Advantage."

Our Promise

Our Promise means your Agilent test and measurement equipment will meet its advertised performance and functionality. When you are choosing new equipment, we will help you with product information, including realistic performance specifications and practical recommendations from experienced test engineers. When you use Agilent equipment, we can verify that it works properly, help with product operation, and provide basic measurement assistance for the use of specified capabilities, at no extra cost upon request. Many self-help tools are available.

Your Advantage

Your Advantage means that Agilent offers a wide range of additional expert test and measurement services, which you can purchase according to your unique technical and business needs. Solve problems efficiently and gain a competitive edge by contracting with us for calibration, extra-cost upgrades, out-of-warranty repairs, and onsite education and training, as well as design, system integration, project management, and other professional engineering services. Experienced Agilent engineers and technicians worldwide can help you maximize your productivity, optimize the return on investment of your Agilent instruments and systems, and obtain dependable measurement accuracy for the life of those products.



Agilent Email Updates

www.agilent.com/find/emailupdates

Get the latest information on the products and applications you select.

Agilent T&M Software and Connectivity

Agilent's Test and Measurement software and connectivity products, solutions and developer network allows you to take time out of connecting your instruments to your computer with tools based on PC standards, so you can focus on your tasks, not on your connections. Visit **www.agilent.com/find/connectivity** for more information.

By internet, phone, or fax, get assistance with all your test & measurement needs

Phone or Fax

United States:

(tel) 800 452 4844

Canada:

(tel) 877 894 4414

(fax) 905 282 6495

China:

(tel) 800 810 0189

(fax) 800 820 2816

Europe:

(tel) (31 20) 547 2323

(fax) (31 20) 547 2390

Japan:

(tel) (81) 426 56 7832

(fax) (81) 426 56 7840

Korea:

(tel) (82 2) 2004 5004

(fax) (82 2) 2004 5115

Latin America:

(tel) (305) 269 7500

(fax) (305) 269 7599

Taiwan:

(tel) 0800 047 866

(fax) 0800 286 331

Other Asia Pacific Countries:

(tel) (65) 6375 8100

(fax) (65) 6836 0252

Email: tm_asia@agilent.com

Online Assistance:

www.agilent.com/find/assist

Product specifications and descriptions in this document subject to change without notice.

© Agilent Technologies, Inc. 2002, 2004

Printed in USA, February 27, 2004

5980-1471E



Agilent Technologies